

# Agile Wall Mounted Unit AG6011

Please retain for future reference

# R2

## Installation and Fitting Instructions

### Before you start

It is recommended that all units and basins are secured to a suitably reinforced wall to ensure stability. Wall plugs are only suitable for solid stone/brick wall. For plasterboard walls use specialist wall plugs, if in any doubt please consult an expert.

Wear suitable eye protection when drilling. Take care when using power tools near water - the use of a residual current device (RCD) is recommended. Beware of hidden pipes or cables. Take care when drilling tiled surfaces as the drill might slip. Use a piece of masking tape to prevent the drill from wandering.

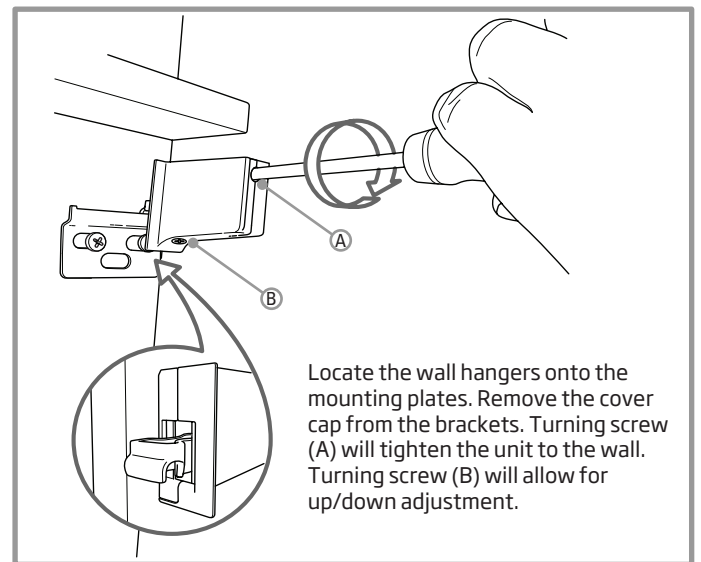
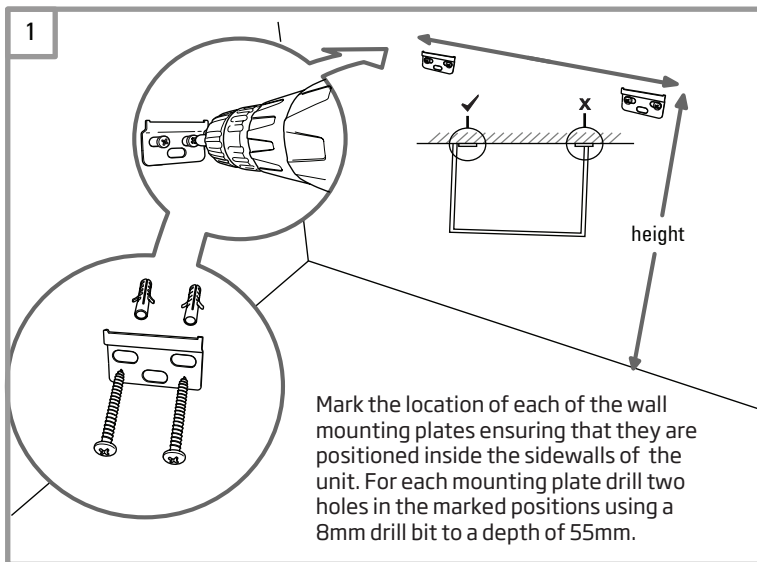

Fascias may require adjustment for correct alignment. This is achieved with the adjusting mechanisms shown in diagrams 3 and 4

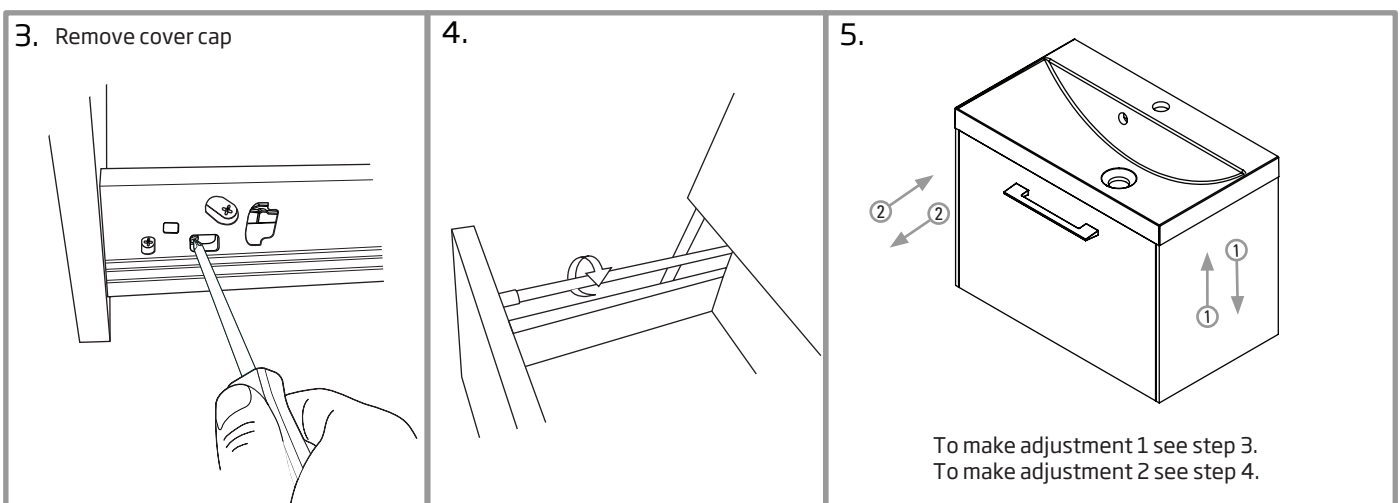

### Fitting Basin

Once the basin has been plumbed in finish by securing the basin to the unit with a silicone sealant.

# Removing Drawer and Fascia

If faulty the drawer fascia can be removed and replaced using the instructions below.

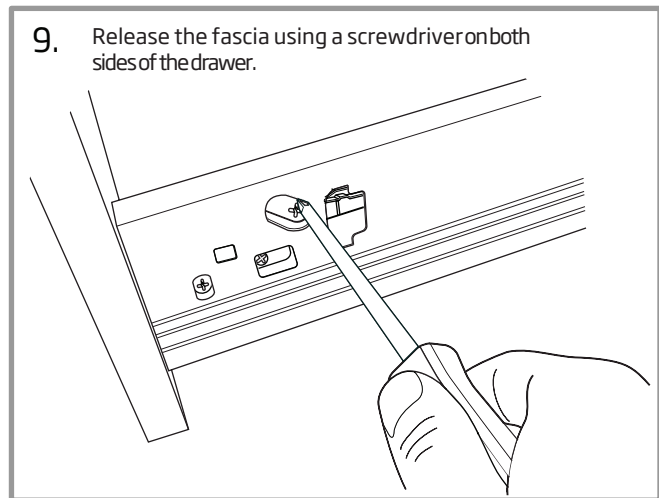
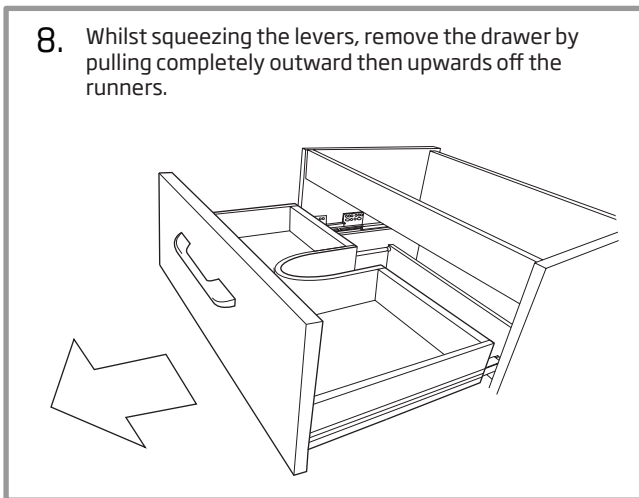
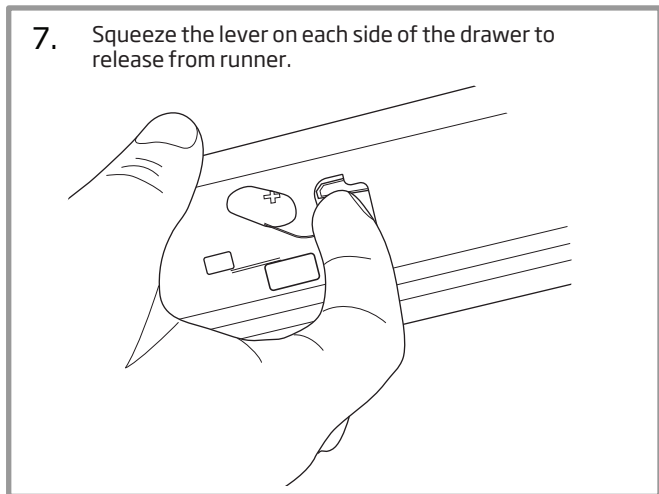
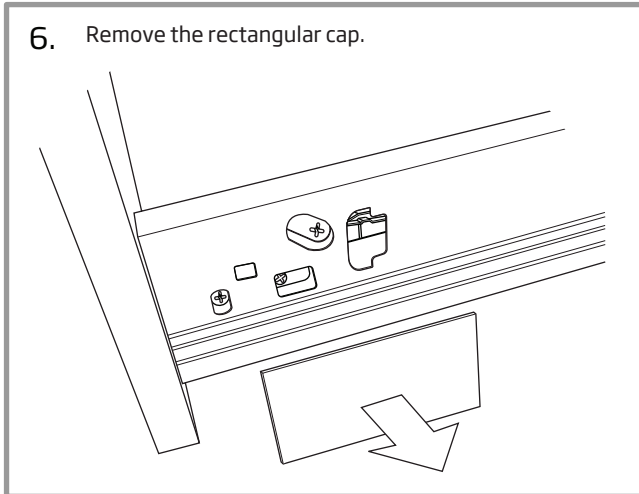

## Furniture Aftercare Instructions

As with all wooden furniture, this unit should be treated with care:



Wipe away any water splashes or condensation after use. Excessive exposure to water will deteriorate the furniture.

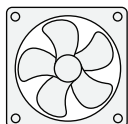

All bathrooms should be well ventilated with a suitable extractor fan.



Clean with a soft damp cloth only.



Use a wax free polish if one must be used.

For removal of lime scale deposits use a suitable proprietary cleaner. If necessary test on an inconspicuous area first.



Do not scrub or scour



Do not use abrasive cleaning agents

### Replacement components

Should you require any replacement components for this product please contact Roper Rhodes Ltd using the contact details below.



Customer Services  
R2  
Brassmill Lane Trading Estate  
Bath  
BA1 3JF  
t: 01225 303900